

尺寸/Dimensions (Unit:mm)

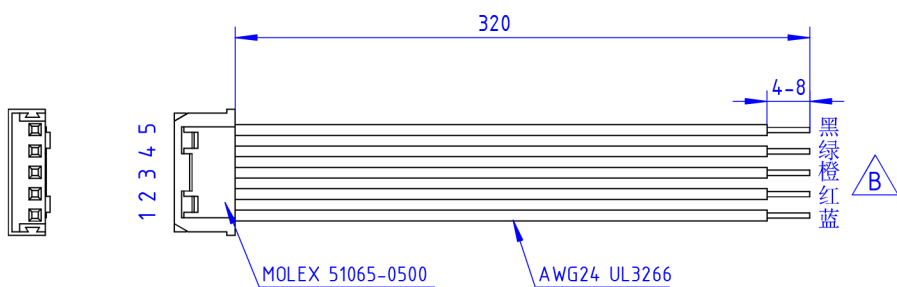

接线图  
Wire Diagram

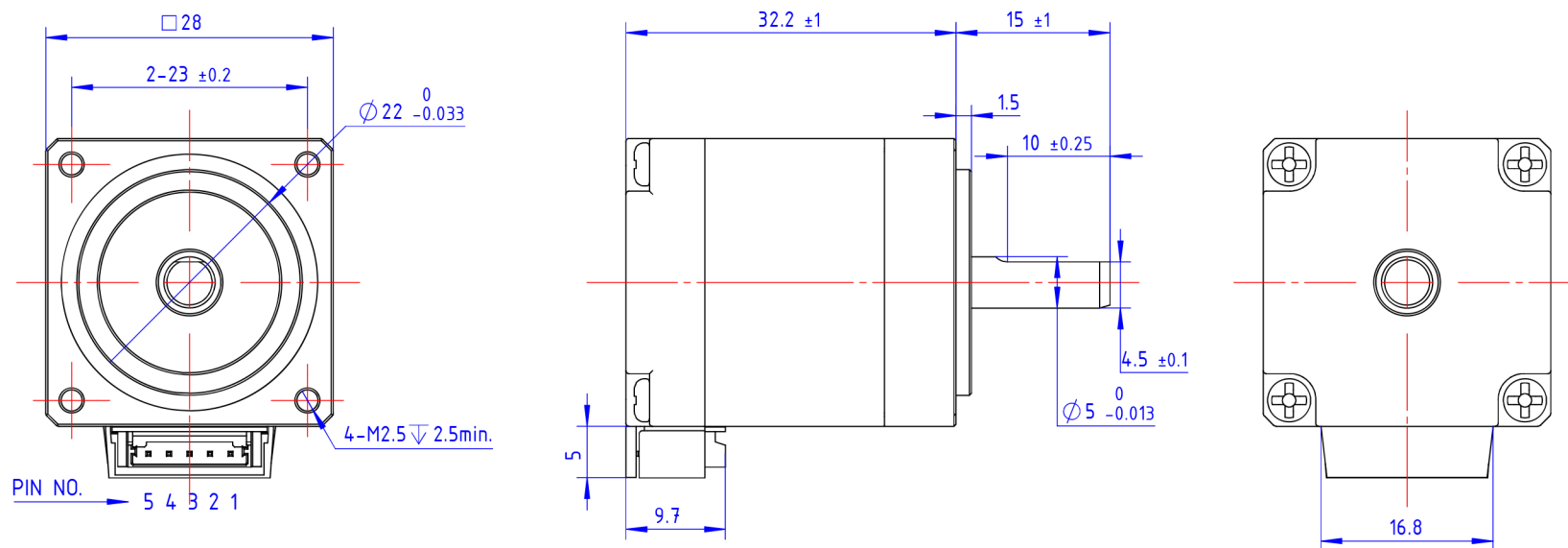
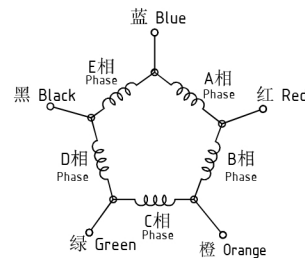

励磁顺序 vs. 旋转方向  
Exciting Sequence vs. Direction of Rotation

STEP	黑 Black	绿 Green	橙 Orange	红 Red	蓝 Blue
1	+	+	-	-	
2	+		-	-	
3	+		-		+
4		-	-		+
5		-		+	+
6	-	-		+	
7	-		+	+	
8	-		+		-
9		+	+	-	-
10		+		-	-

从安装面看为顺时针方向  
Clockwise view from mounting side

电动机规格/Motor Specification

相数/Number of Phase	5
步距角/Step Angle	0.72°±5%
额定电流/Rated Current	1.2A/Phase
相电阻/Phase Resistance(单相电阻)	0.56Ω±10% (@20°C)
相电感/Phase Inductance(单相电感)	~mHz20% (1Vrms, 1kHz)
保持力矩/Holding Torque	0.05N·m MIN.
最大自启动频率/Max Starting Pulse Rate	-
绝缘电阻/Insulation Resistance	100MΩ MIN.
绝缘耐压/Dielectric Strength	AC500V 1"
绝缘等级/Insulation Class	Class B (130°C)
温升/Temperature Rise	80K MAX.
转子惯量/Rotor Inertia	9g·cm²
质量/Mass	0.11kg
寿命/Life	5000 Hours MIN.
使用环境/Operating Environment	-10°C~50°C; 20RH%-90%RH (No condensation)
储存环境/Storage Environment	-20°C~70°C; 15%RH-90%RH (No condensation)

C	2023-04-26		增加励磁顺序表格, 更新电动机规格参数, 更新公司名称
B	2023-02-17		标记处更新线色, 更新电阻参数
A	2022-10-09		初版本
REV.	日期DATE	设计DESIGNED	说明DESCRIPTION
版本记录 REVISION RECORD			
REMARK		混合式步进电动机产品规格书 HYBRID STEPPER MOTOR SPECIFICATION	
表面处理 FINISH		尺寸 SIZE	A3
材质 MATERIAL		比例 SCALE	2:1
第一角画法 FIRST ANGLE PROJECTION			
		产品型号 PART NUMBER <b>LS28D005-B1B12</b>	
		SHEET:1/1	